

スライドレール(ストップタイプ)



SLIDE RAILS

P-502



P-502-30

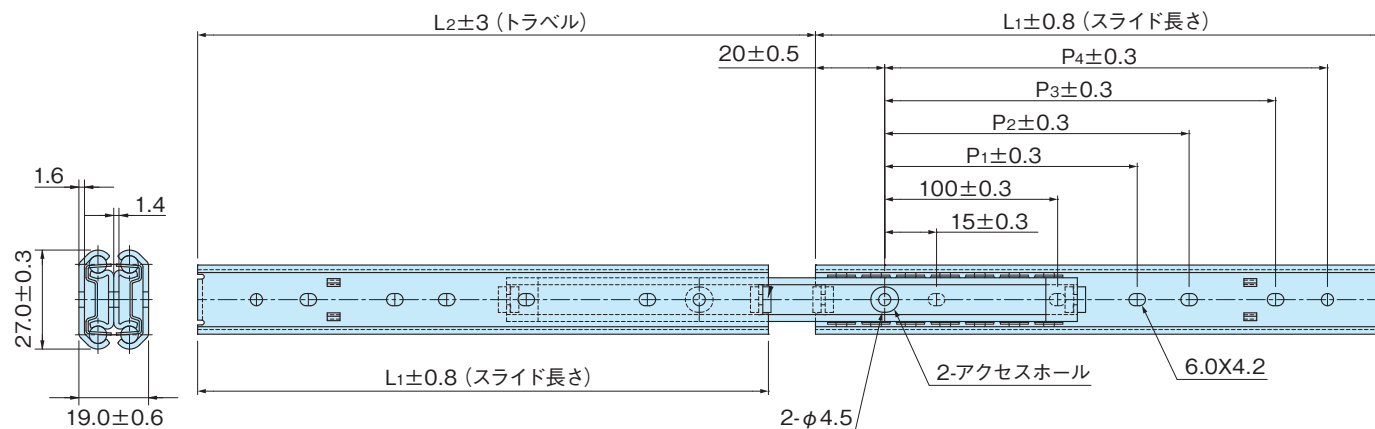

- 特徴**
Feature
- ダブルスライドでフルトラベル仕様になっていますので、インナーレールは全長引き出せます。引抜くことはできません。消音クッション付き。
 - It is possible to pull out the entire length of the inner rail, because of double slide and full travel specification. But, it can not be pulled out. Silence cushion is attached.

- 材質** ●鉄 (SPCC)
表面処理 ●電気亜鉛めっき 光沢クロメート
用途 ●OA機器・医療機器・通信機・各種BOX
備考 ●インナーレールとアウターレールは、必ずSET品ごとにお取りつけください。取り違えて取付けた場合、動作が重くなる場合があります。●市販品につき、ケース単位(入数)でのご注文をお願い致します。

- Material** ●Cold rolled steel plate (SPCC)
Finish ●Electrolytic zinc-coating, Bright chromate
Specific Use ●OA equipment, medical equipment, communications equipment, and various cabinets.
Remarks ●Please install as set product of outer rail and inner rail. If the installation is wrong, there may be cases that the operation of the rail is heavy. ●Please order in case unit (Quantity) about products on the market.

■使用例 Example of application



品番 Product No.	L ₁	L ₂	定格荷重 (N/ペア)	P ₁	P ₂	P ₃	P ₄	自重 (kg/ペア) Weight	入数 Lot	単価 Price
P-502-20	200	230	343			145	160	0.60	30	¥1,250
P-502-25	250	279	353		150.0	195	210	0.77	30	¥1,350
P-502-30	300	328	363		190.0	245	260	0.93	30	¥1,500
P-502-35	350	377	353		225.0	295	310	1.10	30	¥1,600
P-502-40	400	426	333		265.0	345	360	1.26	30	¥1,750
P-502-45	450	476	304	205.0	300.0	395	410	1.43	30	¥1,900
P-502-50	500	525	275	230.0	337.0	445	460	1.59	30	¥2,100