

封印付薄型平面スイングハンドル

THIN FLAT SWING HANDLES WITH SEALING

AB-453F-1



AB-453F-1

- 特 徴** ●封印する事が出来ます。
Feature ●左右兼用設計(左右の変更は止め金と調整座金を裏返してください)
 ●Can be sealed.
 ●For both left and right use (the left and right can be changed by reversing the stopper plate and adjustment washer.)

- 材 質** ●亜鉛合金 (ZDC)
 ●ピン部/ステンレス (SUS304)
表面処理 ●サチライトクロムめっき
用 途 ●配電盤・分電盤・制御盤・その他各種BOX
備 考 ●キー番号/H200

- Material** ●Zinc alloy (ZDC)
 ●Pin/Stainless steel (SUS304)
Finish ●Satellite chrome plating
Specific Use ●Power/distribution boards, control boards, various boxes
Remarks ●Key No/H200

※本製品の止め金取付け用ネジは、緩み防止の為「緩み防止剤」の塗布を推奨致します

品番 Product No.	備考 Remarks	自重(g) Weight	入数 Lot	単価 Price
AB-453F-1	鍵付き	220	80	¥2,400

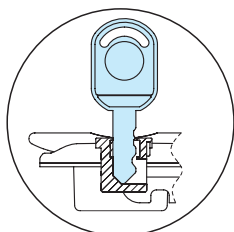
キー番号/H200
Key No.

■使用例 Example of application

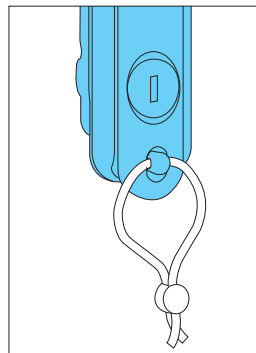

■ AB-453F-1 (キー付) With key

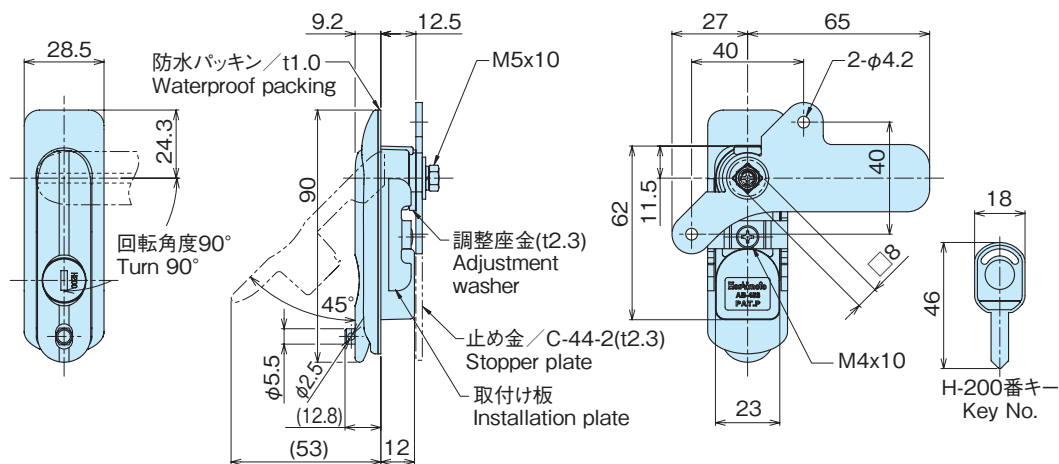
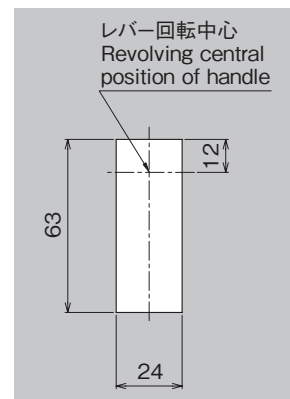
■取付け穴寸法
Dimension of mounting hole

・適用扉板厚は、t1.0~2.5mm
 Panel thickness applicable to install